

Totally enclosed fan-cooled (IE3)(*1)

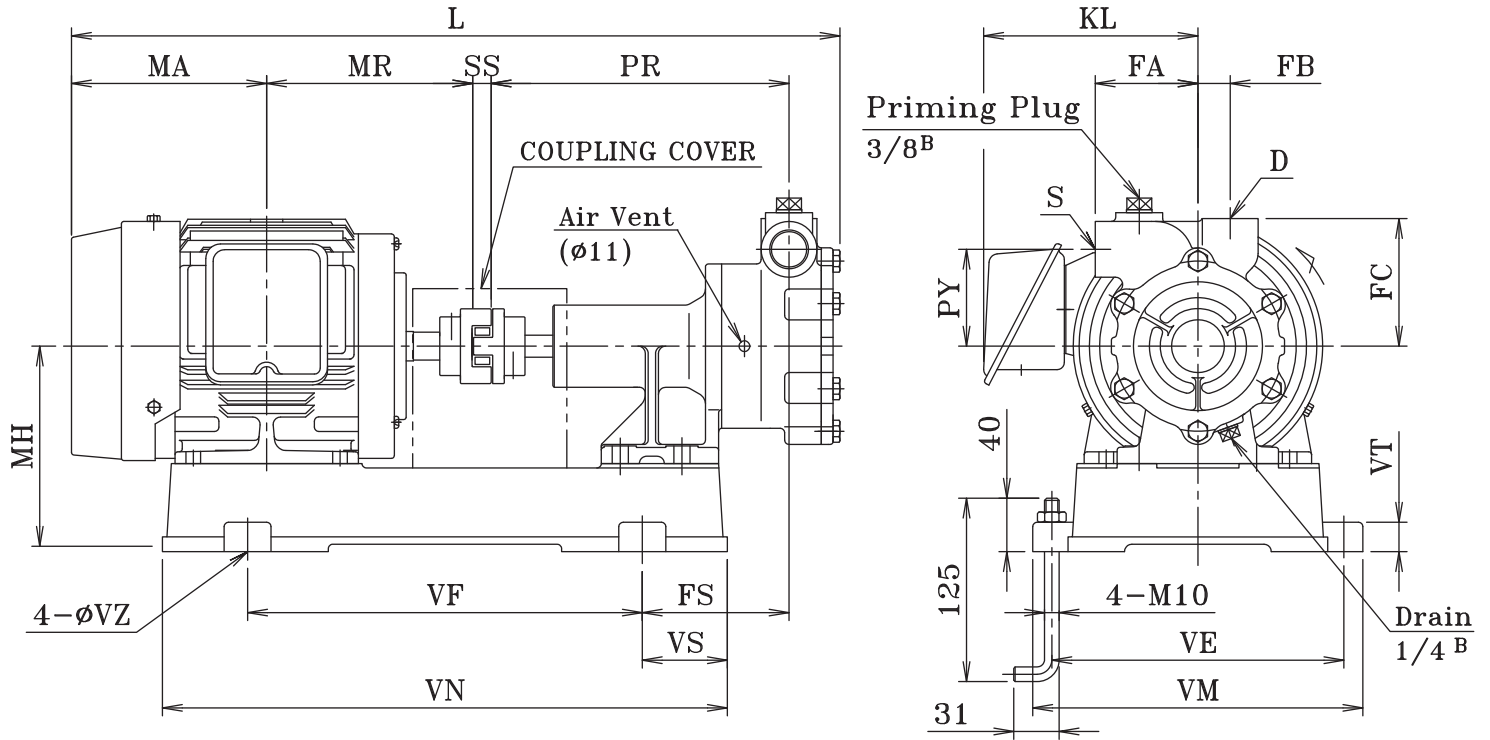

Dimension and Weights

(Unit:mm,kg)

Model	kW	S·D	PR	PY	FA	FB	FS	FC	MH	L	MA	MR	SS	VE	VF	VM	VN	VS	VT	VZ	KL	Weight
20U0	0.2	20A	202	66	70	22	101	87	115	463	109	103	14	170	220	196	335	57	12	12	-	19
	0.4	20A	202	66	70	22	98	87	130	492	121	120	14	184	245	210	357	56	20	12	-	23
	0.75	20A	202	66	70	22	100	87	140	531	140	140	14	199	269	225	385	58	20	12	146	33
25U0	0.4	25A	203.5	70.5	80	26	99.5	99	130	501	121	120	14	184	245	210	357	56	20	12	-	24
	0.75	25A	203.5	70.5	80	26	101.5	99	140	540	140	140	14	199	269	225	385	58	20	12	146	34
	1.5	25A	203.5	70.5	80	26	108.5	99	150	587	154.5	168.5	18	214	300	240	430	65	20	12	156	40
32U0	0.4	32A	203	84	75	30	99	116	130	501	121	120	14	184	245	210	357	56	20	12	-	25
	0.75	32A	203	84	75	30	101	116	140	540	140	140	14	199	269	225	385	58	20	12	146	35
	1.5	32A	203	84	75	30	108	116	150	588	154.5	168.5	18	214	300	240	430	65	20	12	156	41

-Remarks-

Dimensions and weights shown in above table reflected to Totally Enclosed Fan Cooled type motor. Values will be slightly different when other type of motor is being used.

*1 Motor for 0.75kW or greater sizes is complied with IE3 standard.