

Totally enclosed fan-cooled (IE3)(\*1)

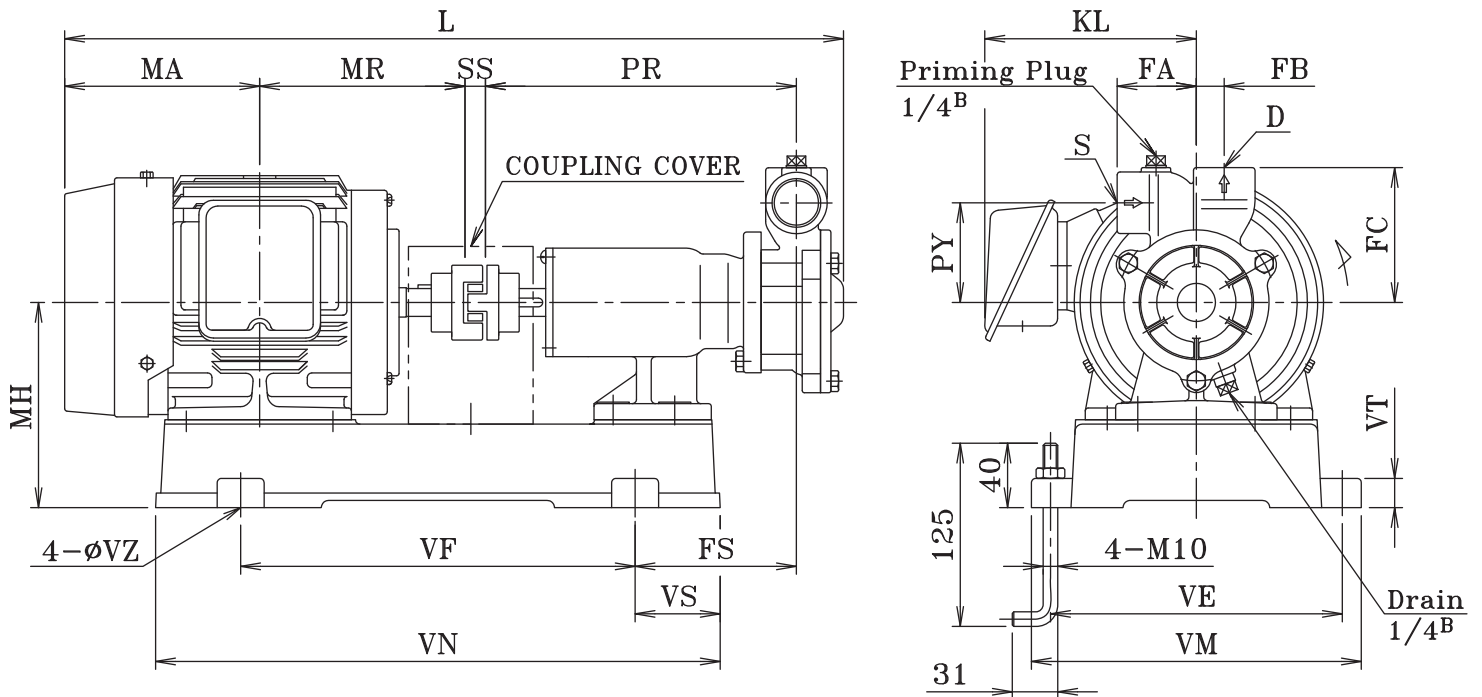

Dimension and Weights

(Unit:mm,kg)

Model	kW	S·D	PR	PY	FA	FB	FS	FC	MH	L	MA	MR	SS	VE	VF	VM	VN	VS	VT	VZ	KL	Weight
15KL-V	0.4	Rc1/2	208	50	40	13	104	70	130	491	121	120	14	184	245	210	357	56	20	12	-	17
20KL-V	0.4	Rc3/4	208	57	45	15	104	77	130	491	121	120	14	184	245	210	357	56	20	12	-	19
	0.75	Rc3/4	208	57	45	15	106	77	140	512	122	140	14	199	269	225	385	58	20	12	146	26
25KL-V	0.75	Rc1	212	68	54	19	110	92	140	520	122	140	14	199	269	225	385	58	20	12	146	26
	1.5	Rc1	212	68	54	19	117	92	150	585	154.5	168.5	18	214	300	240	430	65	20	12	156	35
32KL-V	1.5	Rc1 1/4	211	78	58	24	116	106	150	585	154.5	168.5	18	214	300	240	430	65	20	12	156	36
	2.2	Rc1 1/4	211	78	58	24	116	106	150	585	154.5	168.5	18	214	300	240	430	65	20	12	156	40.5
40KL-V	1.5	Rc1 1/2	210	83	66	27	115	114	150	585	154.5	168.5	18	214	300	240	430	65	20	12	156	36
	2.2	Rc1 1/2	210	83	66	27	115	114	150	585	154.5	168.5	18	214	300	240	430	65	20	12	156	40.5

-Remarks-

Dimensions and weights shown in above table reflected to Totally Enclosed Fan Cooled type motor. Values will be slightly different when other type of motor is being used.

\*1 Motor for 0.75kW or greater sizes is complied with IE3 standard.