

Totally enclosed fan-cooled (IE3)(*1)

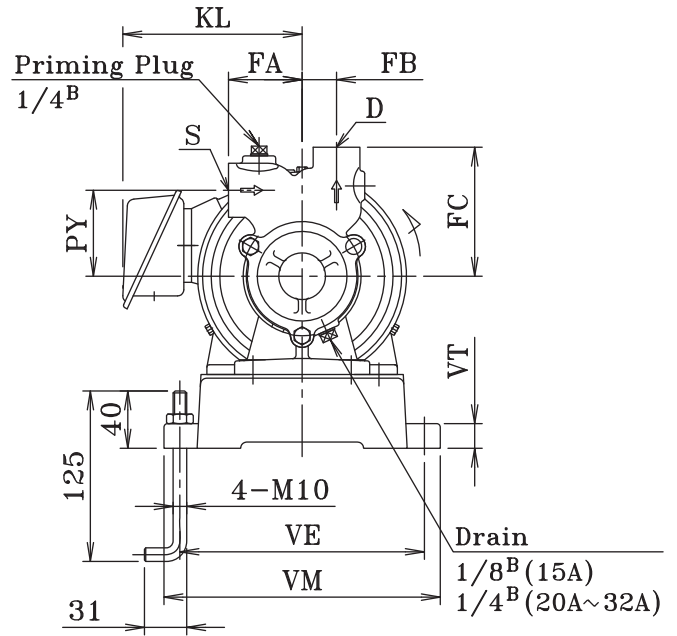
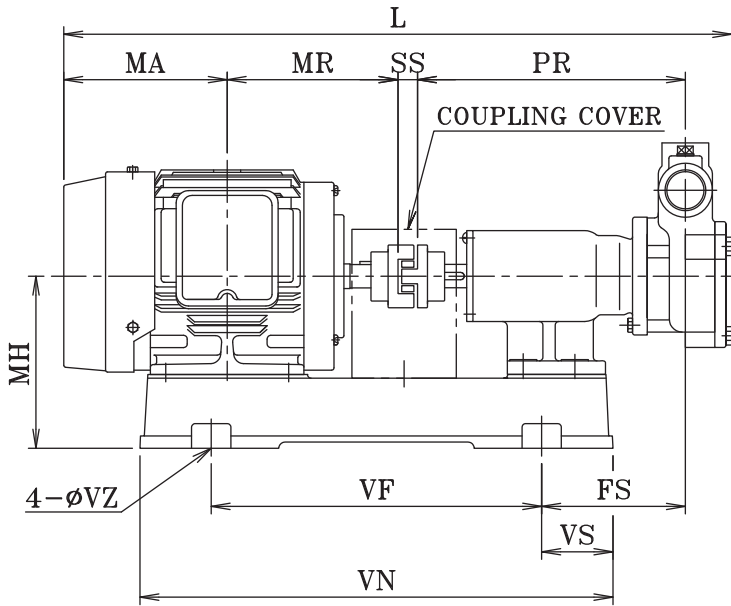

Dimension and Weights

(Unit:mm,kg)

Model	kW	S	D	PR	PY	FA	FB	FS	FC	MH	L	MA	MR	SS	VE	VF	VM	VN	VS	VT	VZ	KL	Weight
15FE	0.4	Rc1/2	Rc3/8	213	52	45	21	109	81	130	499	121	120	14	184	245	210	357	56	20	12	-	18
20FE	0.4	Rc3/4	Rc1/2	214	63	50	25	110	95	130	501	121	120	14	184	245	210	357	56	20	12	-	20
	0.75	Rc3/4	Rc1/2	214	63	50	25	112	95	140	522	122	140	14	199	269	225	385	58	20	12	146	27
25FE	0.75	Rc1	Rc3/4	219	70	60	28	117	105	140	533.5	122	140	14	199	269	225	385	58	20	12	146	27
	1.5	Rc1	Rc3/4	219	70	60	28	124	105	150	598.5	154.5	168.5	18	214	300	240	430	65	20	12	156	36
32FE	1.5	Rc1 1/4	Rc1	224	80	65	35	129	120	150	609	154.5	168.5	18	214	300	240	430	65	20	12	156	37
	2.2	Rc1 1/4	Rc1	224	80	65	35	129	120	150	609	154.5	168.5	18	214	300	240	430	65	20	12	156	41.5

-Remarks-

- Dimensions and weights shown in above table reflected to Totally Enclosed Fan Cooled type motor. Values will be slightly different when other type of motor is being used.
- Suction and discharge flanges are in accordance with JIS 20K FF standard.
- *1 Motor for 0.75 kW or greater sizes is complied with IE3 standard.